

HAMMERHEAD MANUAL MINI-BEAM PRESS

20-50 TON --- DATA SHEET

sales@americanclickerpress.com | www.americanclickerpress.com | (801)613-7997 ext: sales

Front and Rear Light Curtains

Dual Safety Operation Buttons

Emergency Stop Button



Touch Screen Controls

Pneumatic Die Clamping System

Pneumatic Clamping System Toggle

DESIGN, USE, AND FEATURES

- Two-button operational controls
- Touch Screen Controls for Precise Cutting Adjustment
- Anti-Tie-Down Controls and Light Curtains for Safe Operation
- Adjustable Return Height, Cutting Transition Point, and Bottom Hold Time

Data Sheet

Model Number	HH-MBP-20-B
Machine Dimensions (W:D:H)	56" x 77" x 65"
Shipping Dimensions (W:D:H)	56" x 47" x 65"
Cutting Area (W:D)	30" x 30"
Max Die Dimensions (with clamps)	27.5" x 30"
Gross Crated Weight (lbs)	5100
Tonnage	20
Daylight	7.75"
Stroke Adjustment	1.5"-7.75"
Stroke Speed	120mm/s Down 90mm/s Up (Max 10 cycles/min)
Oil Capacity	~20 gallons
Cutting Pad	1" Polypropelene
Machine Power	3 PH, 220V, 60HZ 3 PH, 480V, 60HZ
Amperage (220V/480V)	10.8A/7.6A
Motor Power (kw)	2.2 KW 3 HP

HAMMERHEAD MANUAL MINI-BEAM PRESS

20-50 TON --- DATA SHEET

sales@americanclickerpress.com | www.americanclickerpress.com | (801)613-7997 ext: sales

Machine Width 56"

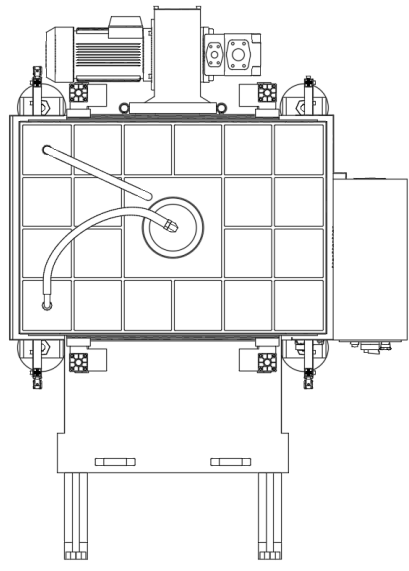

Machine Orthographic View

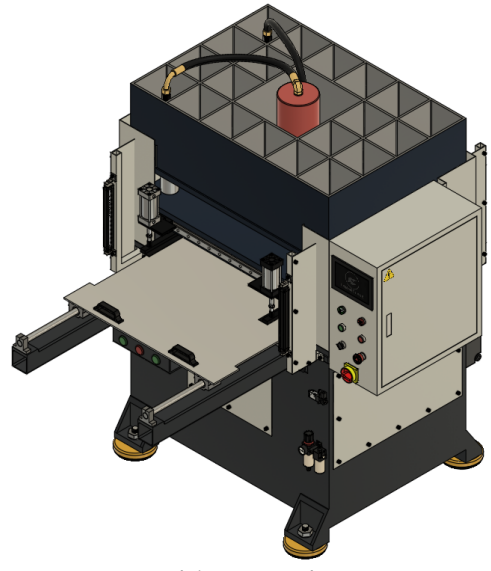

Machine Depth 77"

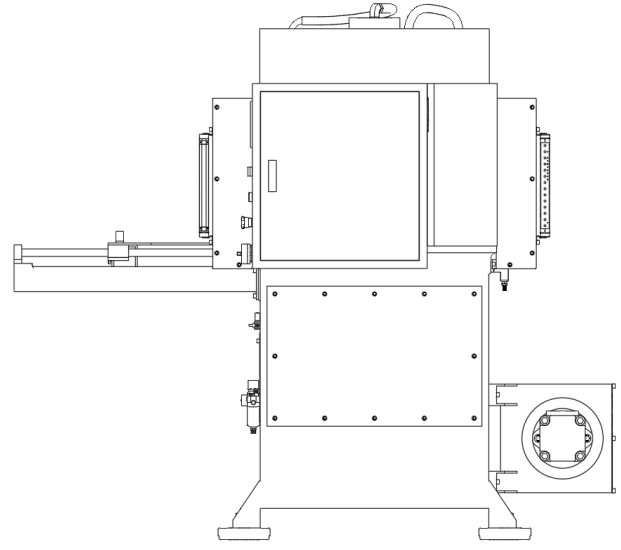

Machine Height 65"

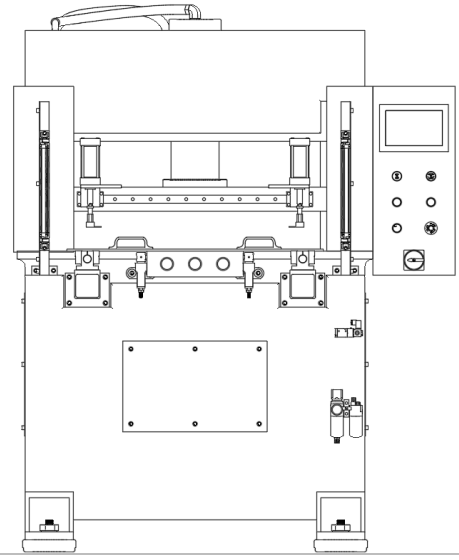

The 30" x 30" HAMMERHEAD mini beam press has ~7.75" of space between the platen and the table when fully open. However, with a ~1" polypropylene cutting board and ~0.25" cutting die the effective stroke of the head is ~6.5".

The footprint of the machine is shown at the widest parts of the profile. Be sure that your workspace can accommodate the machine and the recommended 30" buffer around the machine.

The speed transition point, bottom hold time, and top hold time all allow for additional customization to streamline the cutting process and ensure clean and consistent cuts.