

HAMMERHEAD CONVEYOR MINI-BEAM PRESS

20-50 TON --- DATA SHEET

sales@americanclickerpress.com | www.americanclickerpress.com | (801)613-7997 ext: sales

Front and Rear Light Curtains

Dual Safety Operation Buttons

Emergency Stop Button



Touch Screen Controls

Pneumatic Die Clamping System

Pneumatic Clamping System Toggle

DESIGN, USE, AND FEATURES

- Two-button operational controls
- Compression counter
- Ships with free polypropylene cutting board
- Time-based cutting depth

Data Sheet

| | |
|----------------------------------|--------------------------------------|
| Model Number | HH-CMBP-20-B |
| Machine Dimensions (W:D:H) | 56" x 185" x 65" |
| Shipping Dimensions (W:D:H) | 56" x 185" x 65" |
| Cutting Area (W:D) | 27.5" x 30" |
| Front and Rear Staging Area | 36"/72" |
| Max Die Dimensions (with clamps) | 24.5" x 30" |
| Gross Crated Weight (lbs) | 5250 |
| Tonnage | 20 |
| Daylight | 7.75" |
| Stroke Adjustment | 1.5"-7.75" |
| Stroke Speed | 120mm/s (Max 10 Cycles/Min) |
| Belt Move Speed | 2m/s |
| Oil Capacity | ~20 gallons |
| Cutting Pad | 1" Polypropelene |
| Machine Power | 3 PH, 220V, 60HZ 3 PH, 480V, 60HZ |
| Amperage (220V/480V) | 21.6A/10.2A |
| Motor Power | 2.2 KW 3 HP |

HAMMERHEAD CONVEYOR MINI-BEAM PRESS 20-50 TON --- DATA SHEET

sales@americanclickerpress.com | www.americanclickerpress.com | (801)613-7997 ext: sales

Machine Width 56"

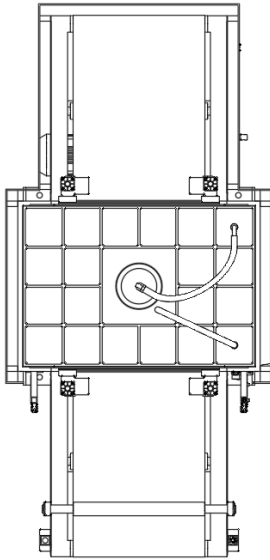

Machine Orthographic View

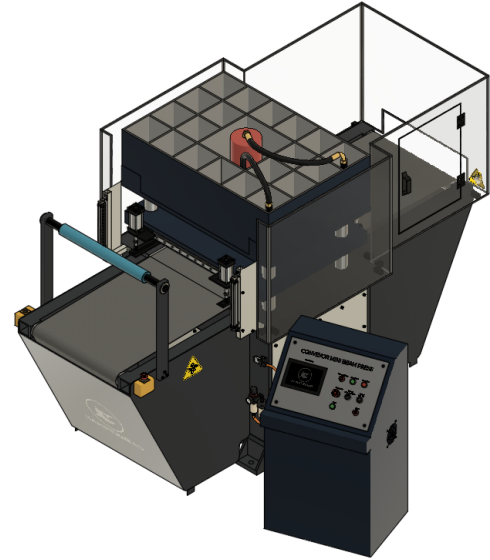

Machine Depth 185

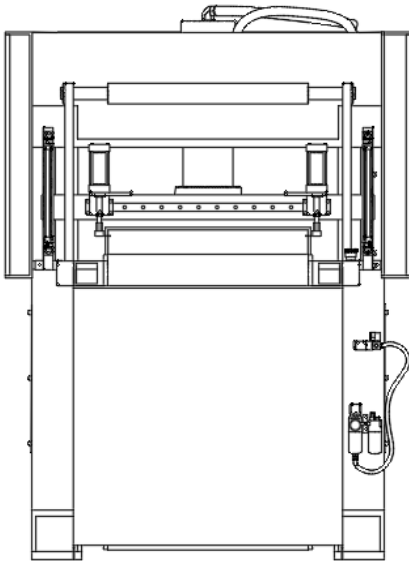

Machine Height 65"

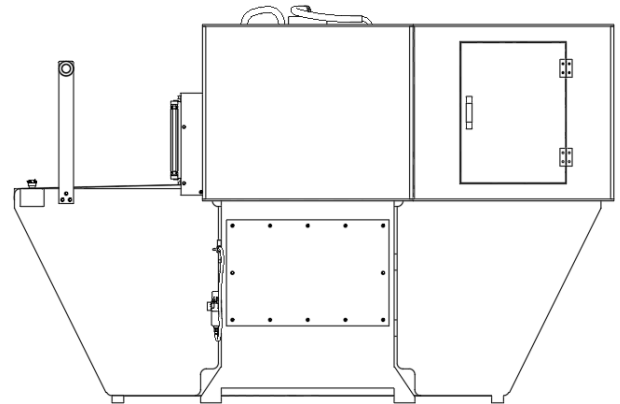

The 30" x 30" HAMMERHEAD mini beam press has ~7.75" of space between the platen and the table when fully open. However, with a ~1" polypropylene cutting board and ~0.25" cutting die the effective stroke of the head is ~6.5".

The footprint of the machine is shown at the widest parts of the profile. Be sure that your workspace can accommodate the machine and the recommended 30" buffer around the machine.

The speed transition point, bottom hold time, and top hold time all allow for additional customization to streamline the cutting process and ensure clean and consistent cuts.